



# HYDRA-TECH PUMPS

## 10" HYDRAULIC SUBMERSIBLE HIGH PERFORMANCE, SOLIDS HANDLING PUMP

### MODEL S6250

10" (250 mm) Discharge

The S6250 is a Solids Handling Effluent Pump for use on jobs such as Waste Treatment, Sewer By-Pass, Barge Transfer, Municipal Lift Stations and Tank Pumping.



## FEATURES

- Balanced High Efficiency Two Vane Closed Channel Impeller
- Will pass 4" (100 mm) semi-solids
- Variable Speed hydraulic drive provides a wide range of performance
- Oil Lubricated Seals (can run dry)
- High Efficiency Balanced Vane hydraulic motor
- Can be bolted directly into a pipeline or used as a booster pump
- Safe Hydraulic Drive can be used where electric power is hazardous or impractical
- Operates with our HT100 to HT200 power units or other hydraulic power sources capable of flows of 50 - 90 GPM

## SPECIFICATIONS

WEIGHT:	800 lbs. (362 kg)
HEIGHT:	43" (109 cm)
WIDTH (@ widest point):	32" (81 cm)
DISCHARGE:	10", 125# ASA Flange
INLET:	10", 125# ASA Flange
SOLIDS HANDLING:	4" (100 mm)
HOSE PORTS:	1-1/4" Code 61 Flange or 1-1/2" NPT (F)
PUMP BODY:	Ductile Iron
IMPELLER:	Ductile Iron
WEAR RING:	Ductile Iron
SHAFT:	17-4 PH Stainless Steel
SHAFT SEAL:	Silicon Carbide
ELASTOMERS:	Buna N (Std)
HYDRAULIC OIL:	214-320 s.s.u. @ 100°F (64°C)
INPUT FLOW:	Max 90 GPM (340 LPM)
OPERATING PRESSURE:	Max 2500 PSI (170 Bar)
POWER SOURCE:	Any Open Center Hydraulic System

B0109

Specifications are subject to change without notice



167 Stock Street, Nesquehoning, PA 18240 Phone: 570-645-3779 Fax: 570-645-4061  
Website: [www.hydra-tech.com](http://www.hydra-tech.com) E-Mail: [htpump@hydra-tech.com](mailto:htpump@hydra-tech.com)

## Model S6250 Overall Dimensions

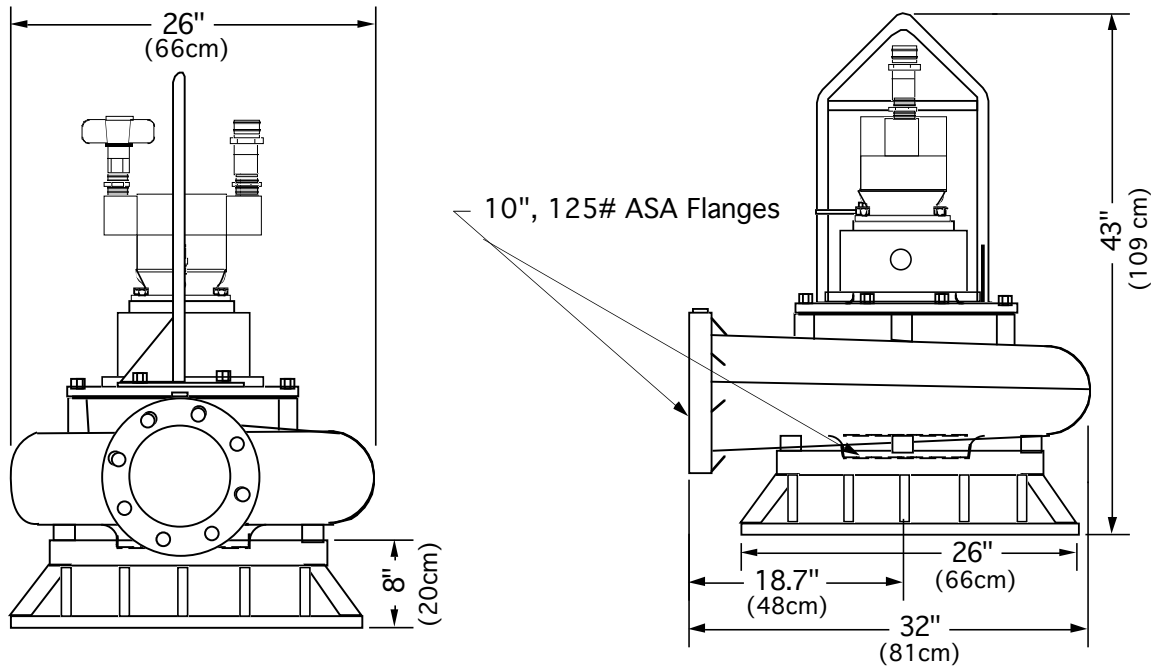

## S6250 Typical Performance

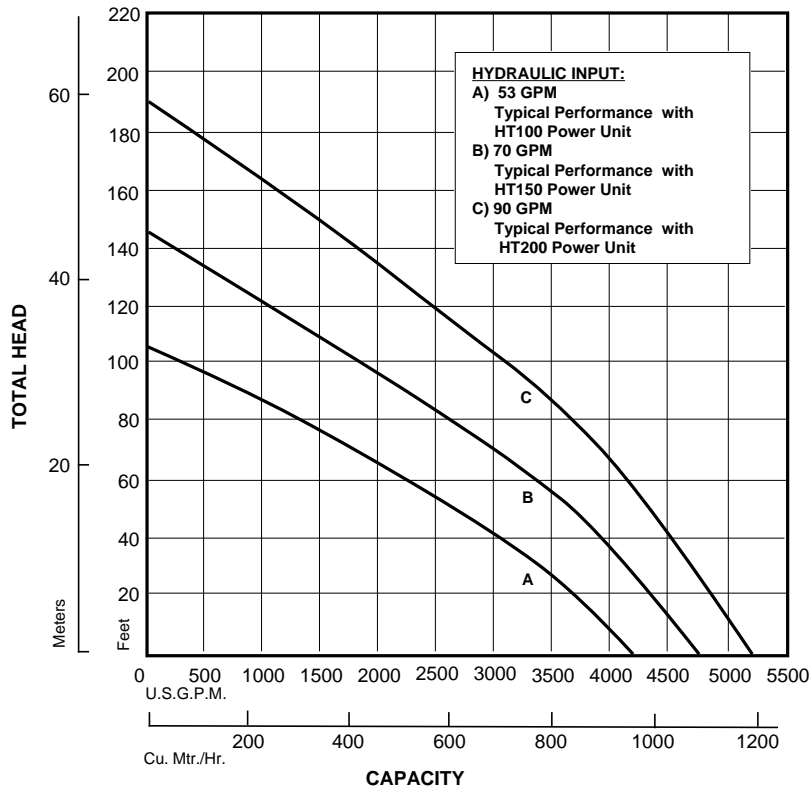

Curves are based on pumping water at 60°F. For performance curves other than shown above, consult factory.



167 Stock Street, Nesquehoning, PA 18240 Phone: 570-645-3779 Fax: 570-645-4061  
 Website: [www.hydra-tech.com](http://www.hydra-tech.com) E-Mail: [htpump@hydra-tech.com](mailto:htpump@hydra-tech.com)