

ACDEU



Diesel Engine Driven Priming Assisted Centrifugal Pump w/Autostart Model PA4A60C-4024T Size 4" x 4"



Total Head		Capacity of Pump in U.S. Gallons per Minute (GPM) at Continuous Performance			
P.S.I.	Feet				
52.9	122	180	180	180	180
52.0	120	220	220	220	220
47.7	110	395	475	475	475
43.4	100	415	565	670	715
39.0	90	420	575	690	805
34.7	80	425	575	705	820
30.3	70	430	580	710	830
26.0	60	435	585	715	835
Suction Lift		25'	20'	15'	10'



PUMP SPECIFICATIONS

Size: 4" x 4" (102 mm x 102 mm) Flanged.
Casing: Gray Iron No. 30. Maximum Operating Pressure 87 psi (601 kPa).*
Semi-Open Type, Two Vane Impeller: Ductile Iron No. 65-45-12.
 Handles 3" (76,2 mm) Diameter Spherical Solids.
Impeller Shaft: Stainless Steel No.17-4
Replaceable Wear Plate: Carbon Steel No. 1015.
Intermediate Bracket: Gray Iron No. 30.
Seal Plate: Gray Iron No. 30.
Seal: Mechanical, Oil-Lubricated, Double Floating, Self-Aligning. Silicon Carbide Rotating and Stationary Faces. Stainless Steel No. 316 Stationary Seat. Fluorocarbon Elastomers (DuPont Viton® or Equivalent). Stainless Steel No. 18-8 Cage and Spring. Maximum Temperature of Liquid Pumped 160°F (71°C).*
Shaft Sleeve: Alloy Steel No. 4130.
Priming Chamber: Gray Iron No. 30.
Discharge Check Valve: Ductile Iron and Buna-N.
Radial Bearing: Open Single Row Ball.
Thrust Bearing: Open Double Row Ball.
Bearing and Seal Cavity Lubrication: SAE No. 30 Non-Detergent Oil.
Flanges: Gray Iron No. 30.
Gaskets: Buna-N, Cork, and Vegetable Fibers.
O-Rings: Fluorocarbon Elastomers (DuPont Viton® or Equivalent).
Hardware: Standard Plated Steel.
Bearing and Seal Cavity Oil Level Sight Gauges.

**Consult Factory for Applications Exceeding Maximum Pressure and/or Temperature Indicated.*

Standard Equipment: Belt-Driven Air Compressor. Hoisting Bail. Combination Skid Base w/Fuel Tank. Strainer. Single Ball Type Float Switch**.

***50 Ft. (15 m) Standard Length; Dual Switches and Alternate Cable Lengths Available From the Factory.*

Optional Equipment: Battery. High Speed (55 MPH/89 KM/H) Wheel Kit with ST205/75R14 Pneumatic Tires. Over-the-Road Trailer (Meets D.O.T. and Transport Canada Requirements) Available w/Either Electric or Hydraulic Surge Brakes, Running Lights, Two Trailer Jack Stands and Safety Chains. EPS w/Submersible Transducer Liquid Level Sensor (50 Ft. [15 M] Cable Standard, Alternate Lengths Available).

WARNING!

Do not use in explosive atmosphere or for pumping volatile flammable liquids.

ENGINE SPECIFICATIONS

Model: John Deere 4024T "Power Tech."
Type: Four Cylinder, Four Cycle, Liquid Cooled Diesel Engine.
Displacement: 149 Cu. In. (2,4 Liters).
Governor: Mechanical.
Lubrication: Forced Circulation.
Air Cleaner: Dry Type.
Oil Reservoir: 8.5 U.S. Qts. (8 Liters) Dry; 7.6 U.S. Qts. (7.2 Liters) Refill.
Fuel Tank: 61 U.S. Gallons (231 Liters).
Full Load Operating Time: 33.7 Hours.
Starter: 12 Volt Electric.

Standard Features: Low Oil Pressure and High Coolant Temperature Safety Shut Down Switches. Autostart Instrument Panel Includes: Tachometer, Voltmeter, Hourmeter, Coolant Temperature Gauge, Oil Pressure Gauge, Manual/Stop/Auto Key Switch, 10 Amp Pushbutton Circuit Breaker, Startup Warning Delay. Muffler w/Guard and Weather Cap. Throttle Control.

JOHN DEERE PUBLISHED PERFORMANCE:
 Maximum Continuous B.H.P. 52 (38.8 kW) @ 2800 RPM
 Maximum Dynamic B.H.P. 61 (45.6 kW) @ 2800 RPM



THE GORMAN-RUPP COMPANY • MANSFIELD, OHIO

GORMAN-RUPP OF CANADA LIMITED • ST. THOMAS, ONTARIO, CANADA

www.grpumps.com

Specifications Subject to Change Without Notice

Printed in U.S.A.

Specification Data

SECTION 42, PAGE 315

APPROXIMATE DIMENSIONS and WEIGHTS

SKID BASE **2-WHEEL**
NET WEIGHT: **2615 LBS. (1186.1 KG.)** **3465 LBS. (1571,7 K.G.)**
SHIPPING WEIGHT: **2890 LBS. (1310,8 KG.)** **3465 LBS. (1571,7 K.G.)**
EXPORT CRATE SIZE: **234 CU. FT. (6,6 CU. M.)**

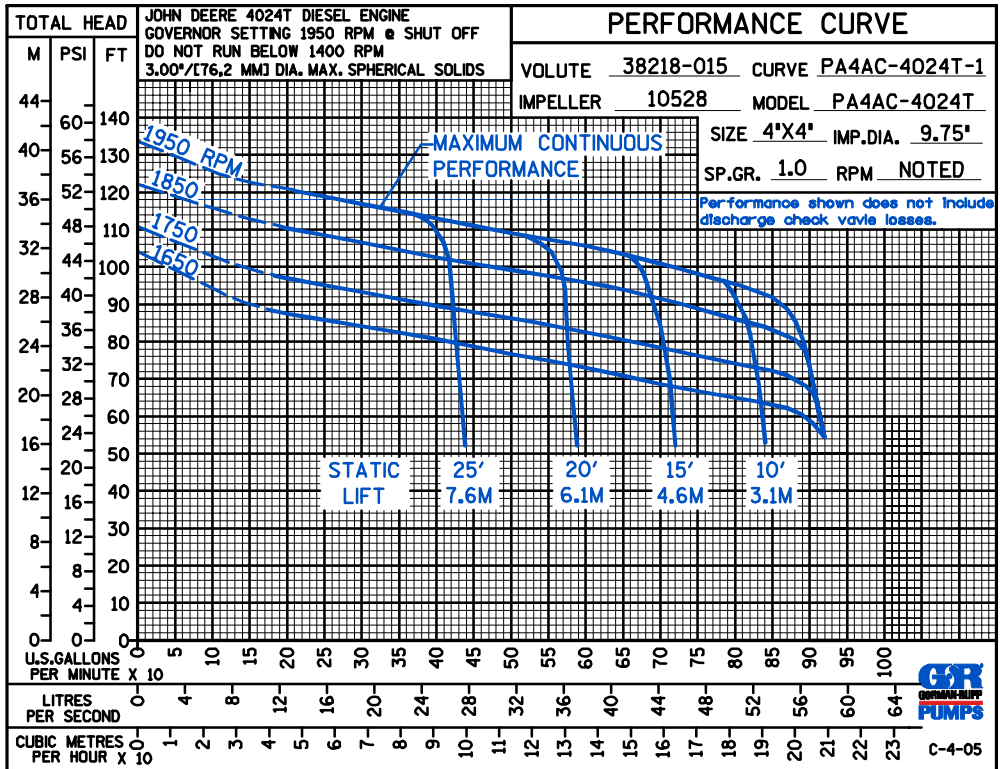
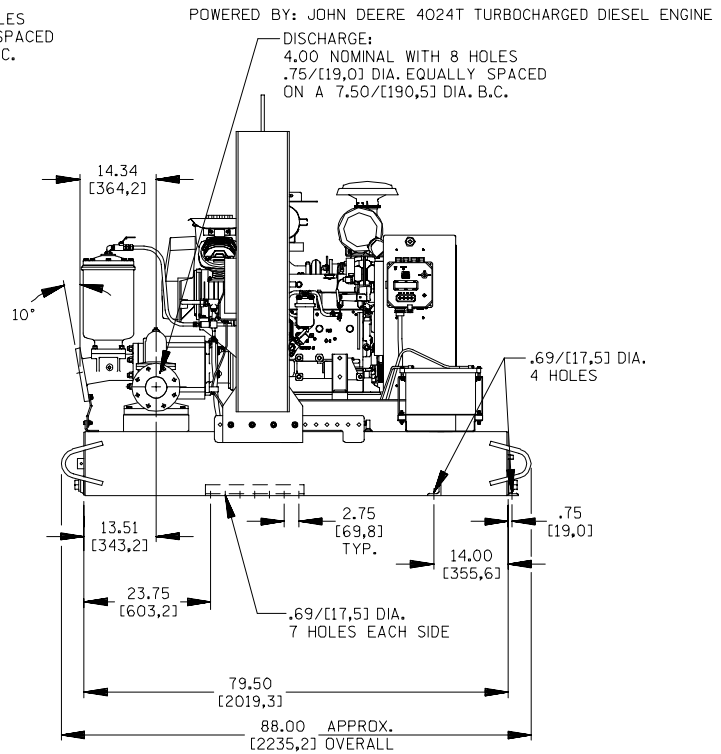
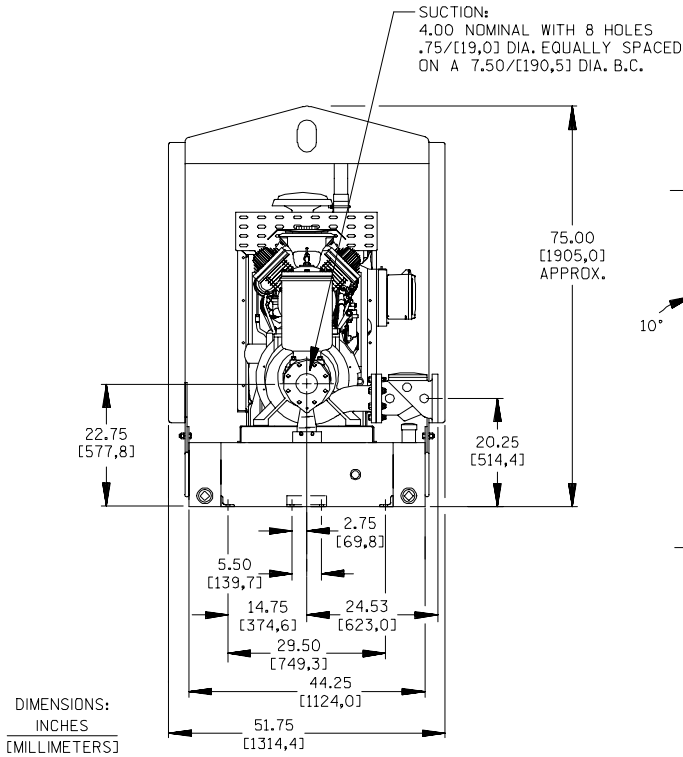

THE GORMAN-RUPP COMPANY • MANSFIELD, OHIO

GORMAN-RUPP OF CANADA LIMITED • ST. THOMAS, ONTARIO, CANADA

Specifications Subject to Change Without Notice

Printed in U.S.A.