



HYDRA-TECH PUMPS

6" HYDRAULIC SUBMERSIBLE VORTEX FLOW TRASH PUMP

MODEL S6T (Aluminum Body)

MODEL S6TDI (Ductile Iron Body)

6" (150 mm) Discharge

The S6T is our most popular 6" Pump. It is lightweight, compact and able to pass large solids, stringy materials and slurries with entrained gases. This versatile top discharge pump is designed for sewer by-pass jobs, digester cleaning, plant intake de-silting and inline pumping.



FEATURES

- Fully Recessed Vortex Impeller (will pass 5" semi-solids)
- Variable Speed hydraulic drive provides a wide range of performance
- Oil Lubricated Seals (can run dry)
- Dependable gear type hydraulic motor
- Can be bolted directly into a pipeline or used as a booster pump
- Safe Hydraulic Drive can be used where electric power is hazardous or impractical
- Optional silt jetting ring is available for agitating solids into suspension
- Operates with our HT50 to HT75 power units or other hydraulic power sources capable of flows of 15 - 30 GPM

SPECIFICATIONS

WEIGHT: (Aluminum).....	195 lbs. (88 kg)
(Ductile Iron).....	340 lbs. (154 kg)
HEIGHT:.....	38" (96 cm)
WIDTH (@ widest point):.....	25" (63 cm)
DISCHARGE:.....	6" NPT(F)
INLET FLANGE:.....	6", 125# ASA
SOLIDS HANDLING:.....	5" (125 mm)
HOSE PORTS:.....	1" (-16) SAE
PUMP BODY: (S6T).....	Heat Treated Aluminum
(S6TDI).....	Ductile Iron
IMPELLER:.....	Stainless Steel
WEAR RING and WEAR PLATE.....	Stainless Steel
SHAFT:.....	Stainless Steel
SHAFT SEAL:.....	Carbon/Ceramic (Std)
	Silicon Carbide (Optional)
ELASTOMERS:.....	Buna N (Std)
HYDRAULIC OIL:.....	214-320 s.s.u. @ 100°F (64°C)
INPUT FLOW:.....	Max 30 GPM (114 LPM)
OPERATING PRESSURE:.....	Max 3000 PSI (204 Bar)
POWER SOURCE:.....	Any Open Center Hydraulic System

F0210

Specifications are subject to change without notice



HYDRA-TECH PUMPS

167 Stock Street, Nesquehoning, PA 18240 Phone: 570-645-3779 Fax: 570-645-4061
Website: www.hydra-tech.com E-Mail: htpump@hydra-tech.com

Model S6T Overall Dimensions

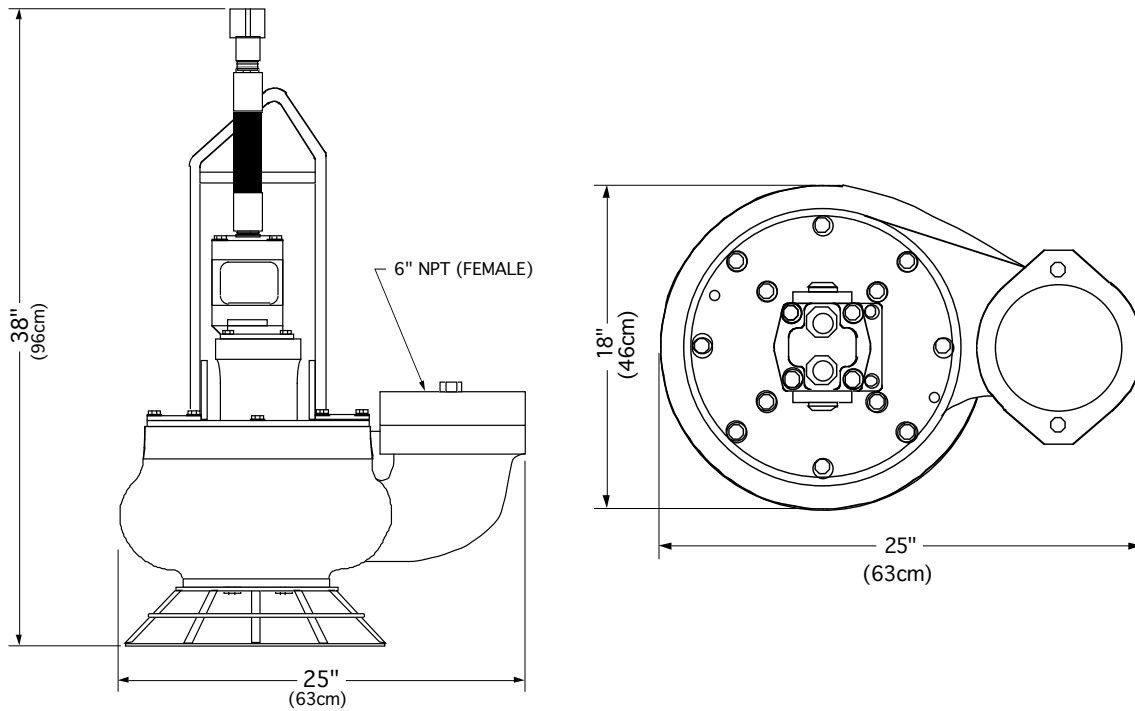

S6T Typical Performance

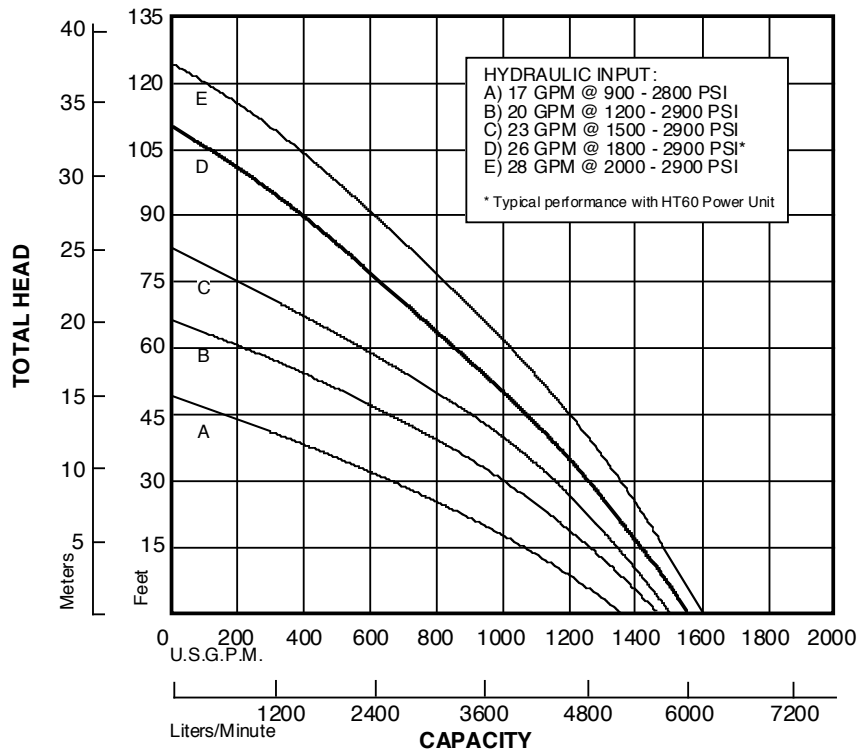

Curves are based on pumping water at 60°F. For performance curves other than shown above, consult factory.



**HYDRA-TECH
PUMPS**

167 Stock Street, Nesquehoning, PA 18240 Phone: 570-645-3779 Fax: 570-645-4061
Website: www.hydra-tech.com E-Mail: htpump@hydra-tech.com