



# HYDRA-TECH PUMPS

## 4" HYDRAULIC SUBMERSIBLE SLUDGE / SLURRY PUMP

**MODEL S4VHL (Aluminum Body)**  
**MODEL S4VHLDI (Ductile Iron Body)**  
4" (100 mm) Discharge

The S4VHL is designed to handle wastewater and sewage and will fit through a 20" diameter manhole . Primary uses for this pump are: Sewer by-pass into force mains and general transfer of solids laden fluids. This versatile pump is offered in aluminum or ductile iron construction.



### FEATURES

- Small Overall Size allows pump to fit through a 20" diameter opening
- Oil Lubricated Seals (can run dry)
- Variable Speed hydraulic drive
- Fully Recessed Vortex Impeller (will pass 3" semi-solids)
- Can be bolted directly into a pipeline or fitted with a suction hose for underwater dredging
- Safe Hydraulic Drive can be used where electric power is hazardous or impractical
- Dependable gear type hydraulic motor
- Operates with our HT25 to HT60 power units or other hydraulic power sources capable of flows of 14 - 26 GPM

### SPECIFICATIONS

WEIGHT: (Aluminum).....	160 lbs. (72 kg)
(Ductile Iron).....	295 lbs. (134 kg)
HEIGHT:.....	33" (84 cm)
WIDTH(@ widest point):.....	19 3/4" (50 cm)
DISCHARGE:.....	4", NPT(F)
INLET FLANGE:.....	4", 125# ASA
SOLIDS HANDLING:.....	3" (8 cm)
HOSE PORTS:.....	1" (-16) SAE
PUMP BODY: (S4VHL).....	Heat Treated Aluminum
(S4VHLDI).....	Ductile Iron
IMPELLER:.....	Stainless Steel
WEAR RING and WEAR PLATE.....	Stainless Steel
SHAFT:.....	Stainless Steel
SHAFT SEAL:.....	Carbon/Ceramic (Std)
	Silicon Carbide (Optional)
ELASTOMERS:.....	Buna N (Std)
HYDRAULIC OIL:.....	214-320 s.s.u. @ 100°F (64°C)
INPUT FLOW:.....	Max 26 GPM (98 LPM)
OPERATING PRESSURE:.....	Max 3000 PSI (204 Bar)
POWER SOURCE:.....	Any Open Center Hydraulic System

B0109

Specifications are subject to change without notice



**HYDRA-TECH PUMPS**

167 Stock Street, Nesquehoning, PA 18240 Phone: 570-645-3779 Fax: 570-645-4061  
Website: [www.hydra-tech.com](http://www.hydra-tech.com) E-Mail: [htpump@hydra-tech.com](mailto:htpump@hydra-tech.com)

## Model S4VHL Overall Dimensions

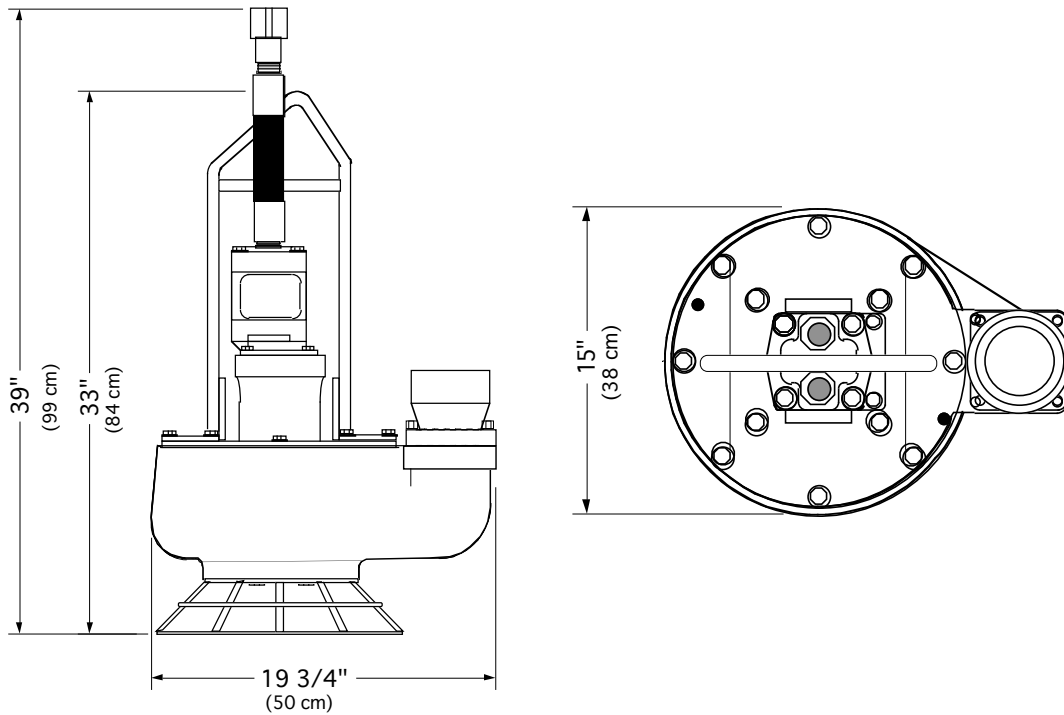

## S4VHL Typical Performance

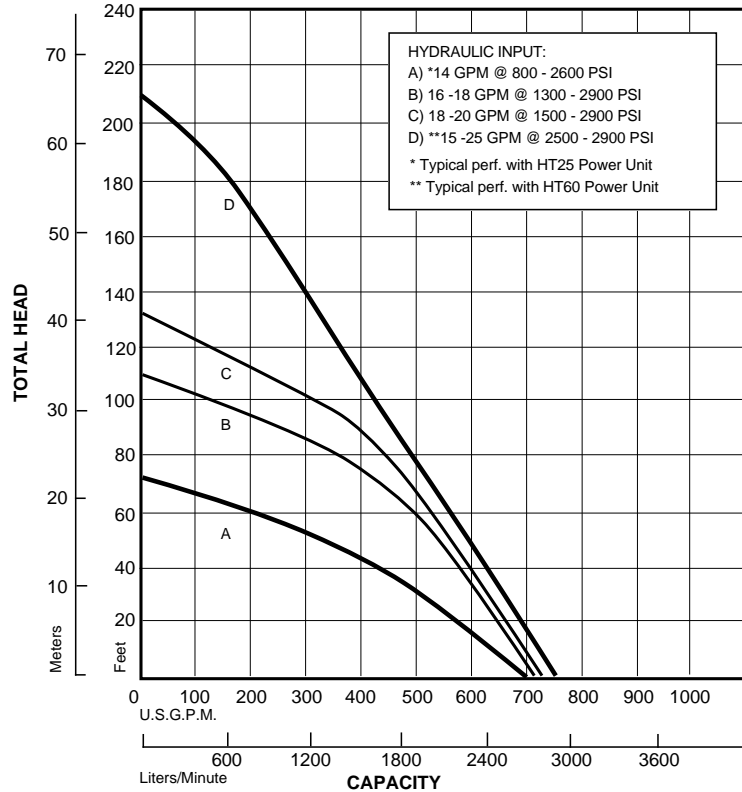

Curves are based on pumping water at 60°F. For performance curves other than shown above, consult factory.



167 Stock Street, Nesquehoning, PA 18240 Phone: 570-645-3779 Fax: 570-645-4061  
 Website: [www.hydra-tech.com](http://www.hydra-tech.com) E-Mail: [htpump@hydra-tech.com](mailto:htpump@hydra-tech.com)